

Phase Control Using Thyristors

Introduction

Due to high volume production techniques, thyristors are now priced so that almost any electrical product can benefit from electronic control. By looking at the fundamentals of SCR and triac phase controls, one can see how this is possible.

Output Power Characteristics

Phase control is the most common form of thyristor power control. The thyristor is held in the "off" condition (all current flow in the circuit is blocked by the thyristor except a minute leakage current). The thyristor is then triggered into an "on" condition by the control circuitry.

For full-wave AC control, a single triac or two SCRs connected in inverse parallel may be used. Two methods may be used for full-wave DC control; either a bridge rectifier formed by two SCRs or an SCR placed in series with a diode bridge as shown in Figure 16.1.

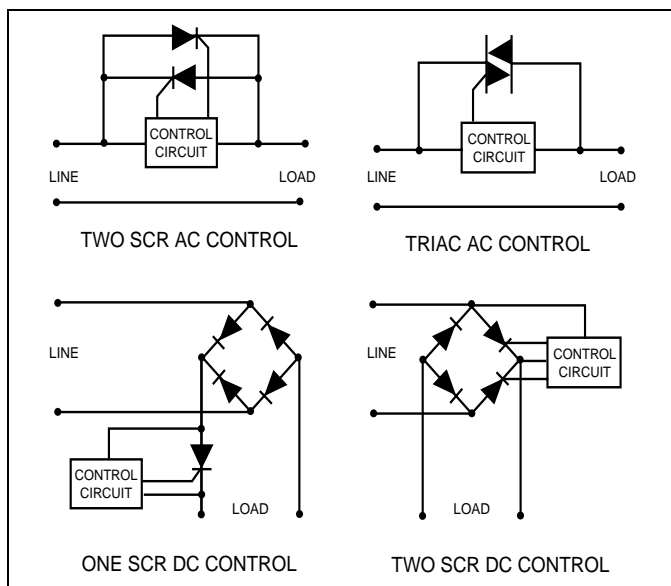

Figure 16.1 SCR/Triac Connections for Various Methods of Phase Control

Voltage waveform and some common terms used to describe thyristor operation are illustrated in Figure 16.2. Delay angle is the time during which the thyristor blocks the line voltage. The conduction angle is the time during which the thyristor is on.

It is important to note that the circuit current is determined by the load and power source. For simplification purposes, assume the load is resistive; hence, both the voltage and current waveforms are identical.

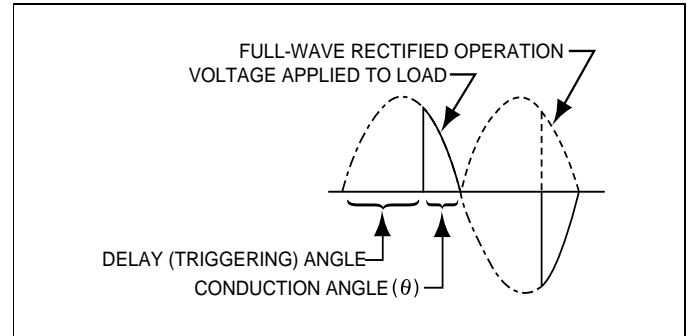

Figure 16.2 Sine Wave Showing Principles of Phase Control

Different loads respond to different characteristics of the AC waveform. For example, some are sensitive to average voltage, some to RMS voltage, and others to peak voltage. Various voltage characteristics are plotted against conduction angle for half- and full-wave phase control circuits in Figures 16.3 and 16.4.

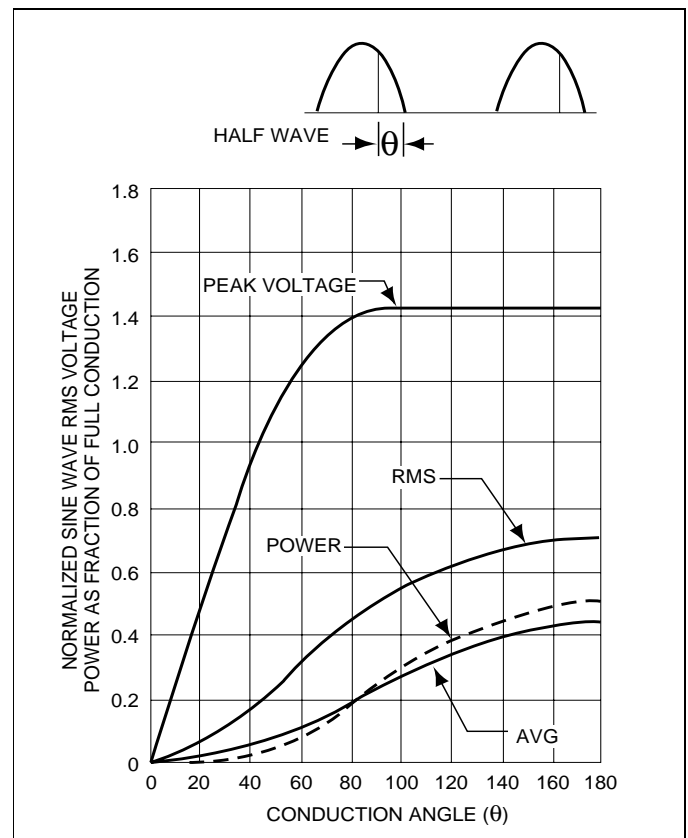

Figure 16.3 Half-Wave Phase Control (sinusoidal)

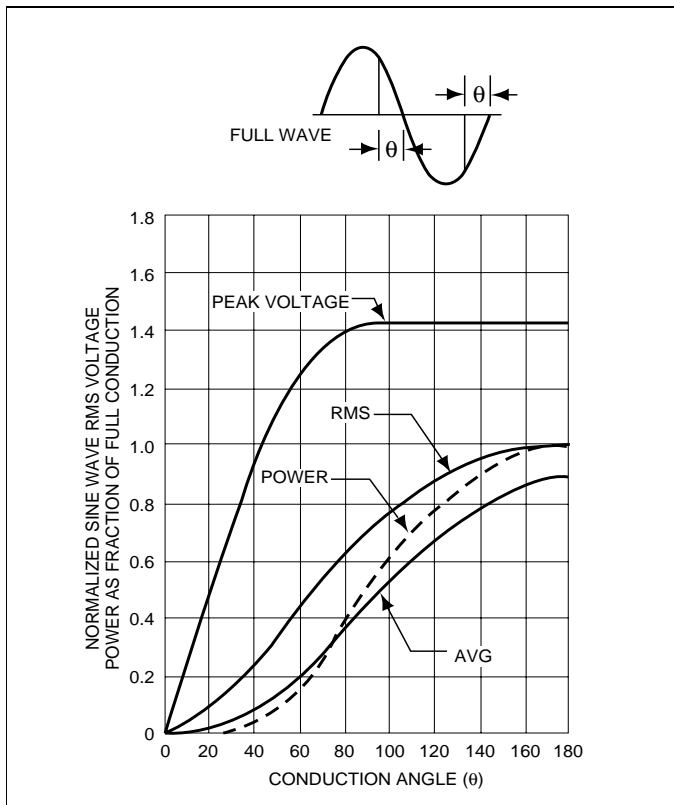

Figure 16.4 Symmetrical Full-Wave Phase Control (sinusoidal)

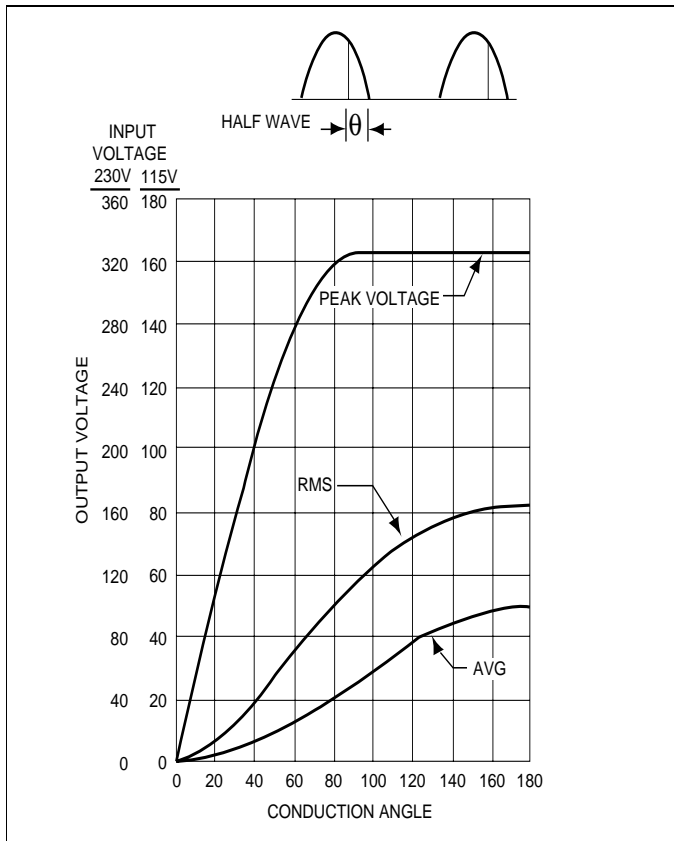

Figure 16.5 Output Voltage of Half-Wave Phase

Figures 16.5 and 16.6 give convenient direct output voltage readings for 115V/230V input voltage. These curves also apply to current in a resistive circuit.

Figures 16.3 and 16.4 show the relative power curve for constant impedance loads such as heaters. The relative impedance of incandescent lamps and motors changes with applied voltage, so they do not follow this curve precisely. To use the curves, find the full-wave rated power of the load, then multiply by the ratio associated with the specific phase angle. Thus, a 180° conduction angle in a half-wave circuit provides 0.5 x full-wave conduction power.

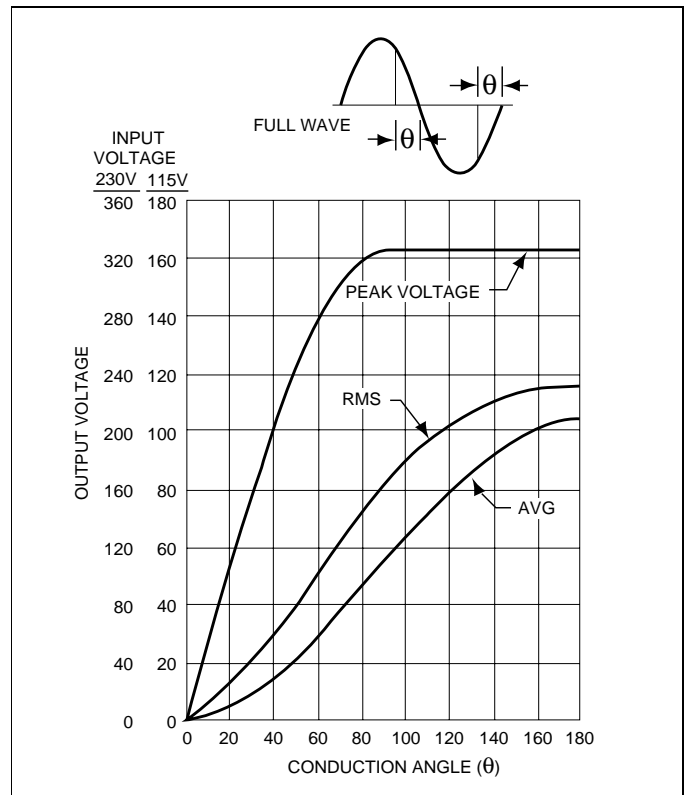

Figure 16.6 Output Voltage of Full-Wave Phase Control

In a full-wave circuit, a conduction angle of 150° provides 97% full power while a conduction angle of 30° provides only 3% of full power control. Therefore, it is usually pointless to obtain conduction angles less than 30° or greater than 150°.

Control Characteristics

A relaxation oscillator is the simplest and most common control circuit for phase control. Figure 16.7 illustrates this circuit as it would be used with a thyristor. The capacitor is charged through the resistor from a voltage or current source until the breakover voltage of the switching device is reached, then the switching device changes to its "on" state, and the capacitor is discharged through the thyristor gate, thus, turn-on of the thyristor is accomplished. Trigger devices used are neon bulbs, unijunction transistors, and three-, four-, or five-layer semiconductor trigger devices. By varying the RC time constant of the charging circuit so the trigger device breakdown occurs at different phase angles within the controlled half or full cycle, phase control of the output waveform is obtained.

Phase Control Using Thyristors

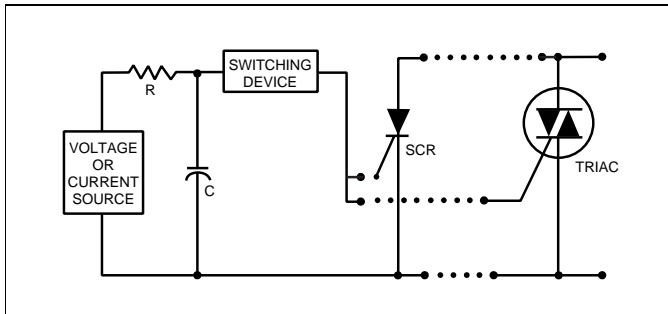

Figure 16.7 Relaxation Oscillator Thyristor Trigger Circuit

Figure 16.8 shows the capacitor voltage-time characteristic if the relaxation oscillator is to be operated from a pure DC source.

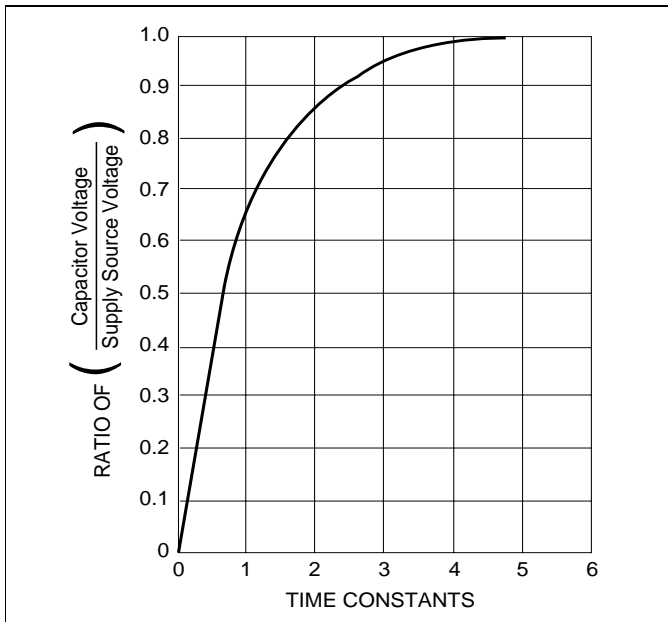

Figure 16.8 Capacitor Charging from DC Source

Usually, the design starting point is the selection of a capacitance value which will reliably trigger the thyristor when the capacitance is discharged. Trigger devices and thyristor gate triggering characteristics play a part in the selection. All the device characteristics are not always completely specified in applications, so experimental determination is sometimes needed.

When final selection of the capacitor is made, Figure 16.8 may be used in determining the charging resistance needed to obtain the desired control characteristics.

Many circuits begin each half-cycle with the capacitor voltage at or near zero. However, most circuits leave a relatively large residual voltage on the capacitor after discharge. Therefore, the charging resistor must be determined on the basis of additional charge necessary to raise the capacitor to trigger potential.

This procedure is best demonstrated with an example. Assume that we want to trigger an S2010L SCR with a 32 volt trigger diac. A $0.1\mu\text{F}$ capacitor will supply the necessary SCR gate current with the trigger diac. Assume a 50 volt DC power supply, 30° minimum conduction angle and 150° maximum conduction angle with a 60 Hz input power source. At approximately 32 volts, the diac triggers and leaves 10 volts

on the capacitor after firing. In order to trigger, 22 volts must be added to the capacitor potential, and 40 volts additional (50-10)

are available. The capacitor must be charged to 22/40 or 0.55 of the available charging voltage in the desired time. From Figure 16.8, 0.55 of charging voltage represents 0.8 time constant. The 30° conduction angle required the firing pulse be delayed 150° or 6.92 milliseconds. (8.33 milliseconds is the period of $1/2$ cycle at 60 Hz.) To obtain this time delay,

$$6.92 \text{ ms} = 0.8 \text{ RC}$$

$$\text{RC} = 8.68 \text{ ms}$$

$$\text{if } C = 0.10\mu\text{F}$$

$$\text{then, } R = \frac{8.68 \times 10^{-3}}{0.1 \times 10^{-6}} = 86,800 \text{ Ohms}$$

To obtain the minimum R (150° conduction angle), the delay is 30° or,

$$(30/180) \times 8.33 = 1.39 \text{ ms}$$

$$1.39 \text{ ms} = 0.8 \text{ RC}$$

$$\text{RC} = 1.74 \text{ ms}$$

$$R = \frac{1.74 \times 10^{-3}}{0.10 \times 10^{-6}} = 17,400 \text{ Ohms}$$

Using practical values, a 100K Ohm potentiometer with up to 17K minimum (residual) resistance should be used. Similar calculations using conduction angles between the maximum and minimum values will give control resistance versus power characteristic of this circuit.

Triac Phase Control

The basic full-wave triac phase control circuit shown in Figure 16.9 requires only four components. Adjustable resistor R_1 and C_1 are a single-element phase-shift network. When the voltage across C_1 reaches breakover voltage, V_{BO} , of the diac, C_1 is partially discharged by the diac into the triac gate. The triac is then triggered into the conduction mode for the remainder of that half-cycle. In this circuit, triggering is in Quadrants I and III. The unique simplicity of this circuit makes it suitable for many applications with small control range.

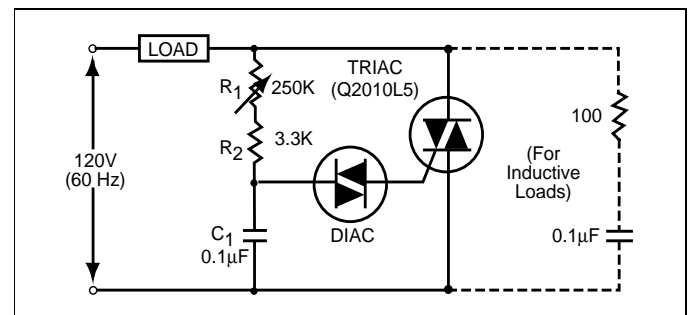

Figure 16.9 Basic Diac-Triac Phase Control

The hysteresis, or "snap back," effect is somewhat similar to the action of a kerosene lantern. That is, when the control

knob is first rotated from the off condition, the lamp can be "lit" only at some intermediate level of brightness, similar to turning up the wick to light the lantern. Brightness can then be turned down until it finally reaches the extinguishing point. If this occurs, the lamp can only be "relit" by turning up the control knob again to the intermediate level. The hysteresis effect in capacitor-diac triggering is illustrated in Figure 16.10. As R_1 is brought down from its maximum resistance, the voltage across the capacitor increases until the diac first fires at point A, at the end of a half-cycle (conduction angle ϕ). After the gate pulse, however, the

capacitor voltage drops suddenly to about half the triggering voltage, giving the capacitor a different initial condition. The capacitor charges to the diac triggering voltage at point B in the next half-cycle, giving a steady state conduction angle shown as θ for the triac.

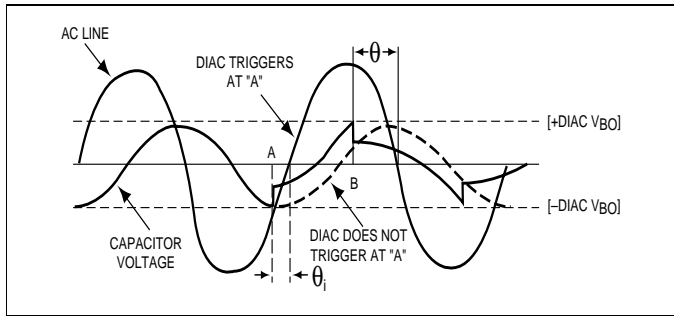

Figure 16.10 Relationship of AC Line Voltage and Triggering Voltage

In Figure 16.11, the addition of a second RC phase-shift network extends the range on control and reduces the hysteresis effect to a negligible region. This circuit will control from 5% to 95% of full load power, but is subject to supply voltage variations. When R_1 is large, C_1 is charged primarily through R_3 from the phase-shifted voltage appearing across C_2 . This action provides additional range of phase-shift across C_1 and enables C_2 to partially recharge C_1 after the diac has triggered, thus reducing hysteresis. R_3 should be adjusted so that the circuit just drops out of conduction when R_1 is brought to maximum resistance.

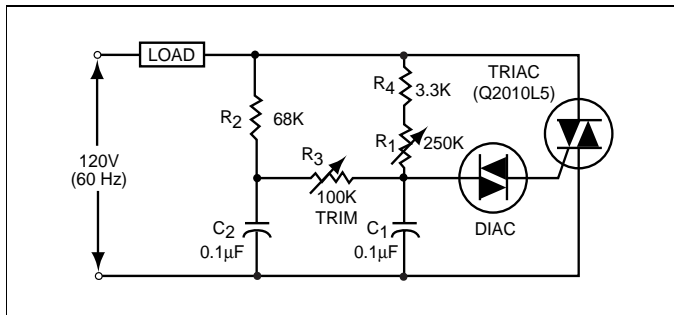

Figure 16.11 Extended Range Full Wave Phase Control

By using one of the circuits of Figure 16.12, the hysteresis effect can be eliminated entirely. The circuit of (a) in Figure 16.12 resets the timing capacitor to the same level after each positive half-cycle, providing a uniform initial condition for the timing capacitor. This circuit is only useful for resistive loads since the firing angle is not symmetrical throughout the range. If symmetrical firing is required, use the circuit of (b) in Figure 16.12.

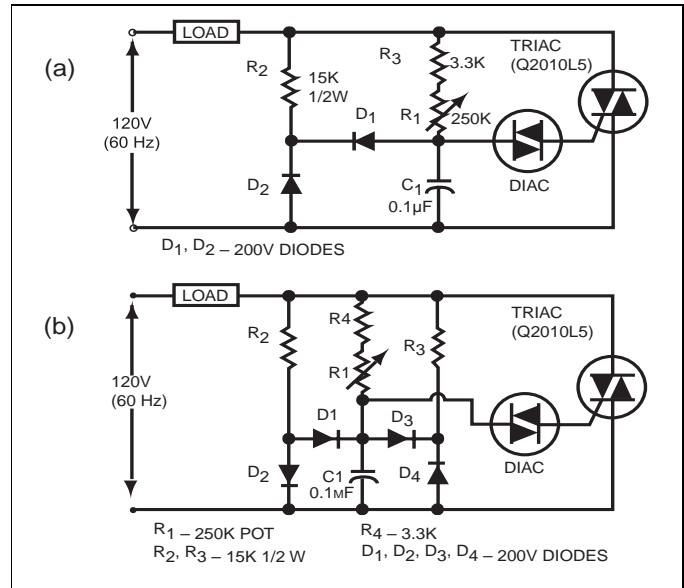

Figure 16.12 Wide Range Hysteresis Free Phase Control

For more complex control functions, particularly closed loop controls, the unijunction transistor may be used for the triggering device in a ramp and pedestal type of firing circuit as in Figure 16.13.

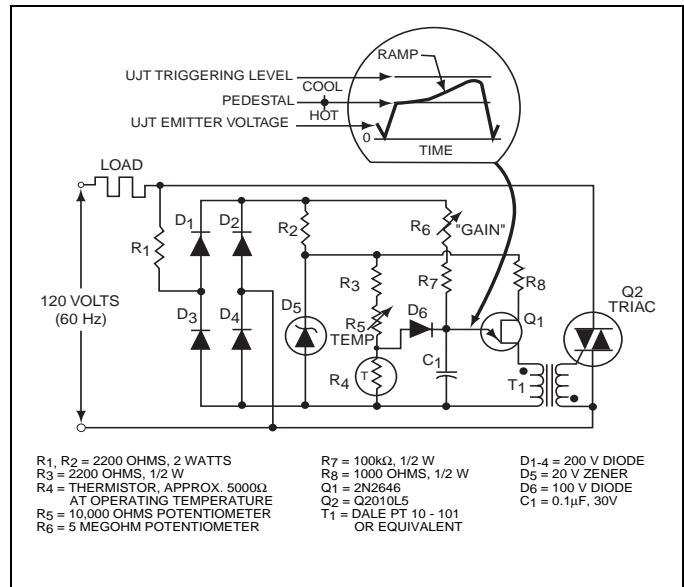

Figure 16.13 Precision Proportional Temperature Control

Several speed control and light dimming (phase) control circuits have been presented that give details for a complete 120V application circuit but none for 240V. The following provide some standard phase control circuits for 240V, 60Hz/50Hz operation along with 120V values for comparison. Even though there is very little difference, there are a few key things which must be remembered. First, capacitors and triacs connected across the 240V line must be rated at 400V. Secondly, the potentiometer (variable resistor) value must change considerably to obtain the proper timing or triggering for 180° in each half-cycle.

Figure 16.14 presents a simple single-time-constant light dimmer (phase control) circuit giving values for both 120V and 240V operation.

Phase Control Using Thyristors

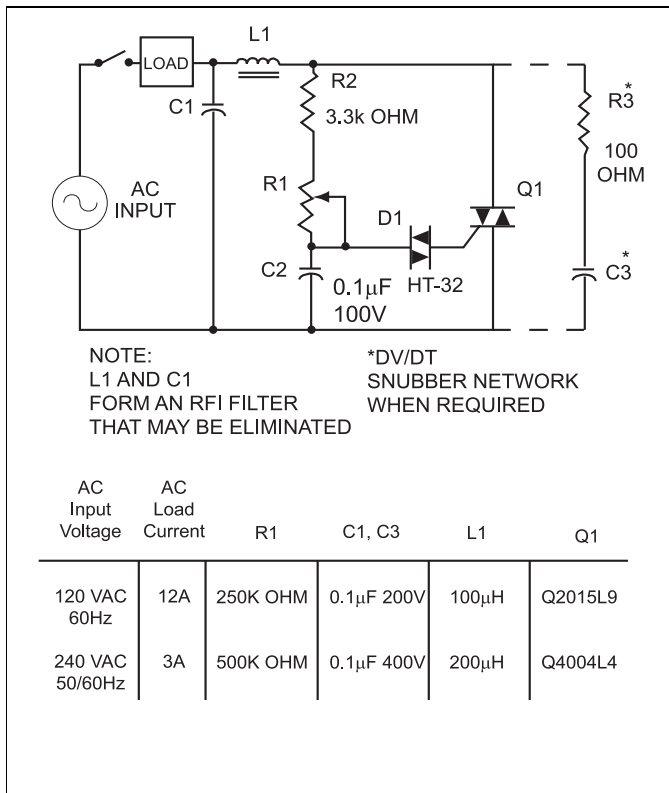

Figure 16.14 Single-Time-Constant Circuit for Incandescent Light Dimming, Heat Control, and Motor Speed Control

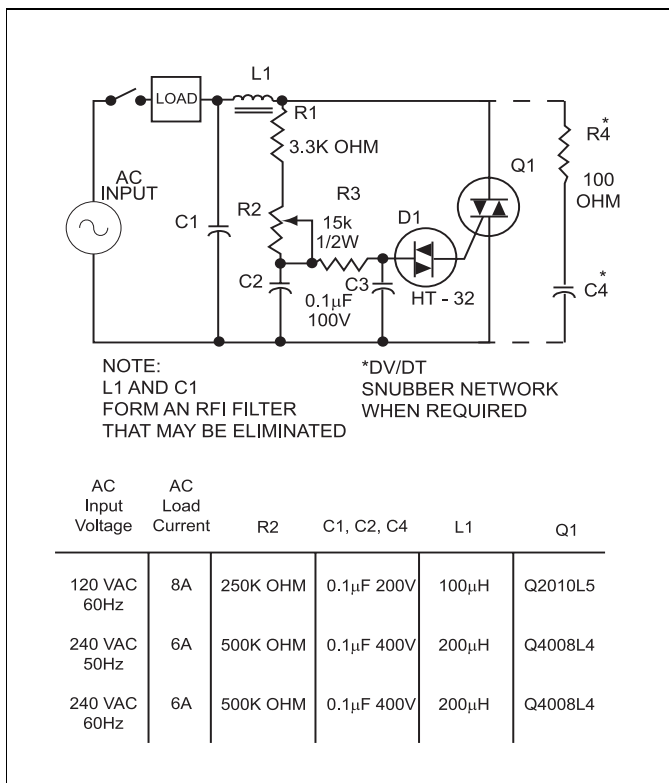

Figure 16.15 Double-Time-Constant Circuit for Incandescent Light Dimming, Heat Control, and Motor Speed Control

Figure 16.15 is a double-time-constant circuit which has improved performance in comparison to Figure 16.14. This circuit uses an additional RC network to extend the phase angle so that the triac can be triggered at small conduction angles. The additional RC network also minimizes any hysteresis effect previously explained and illustrated in Figures 16.10 and 16.11.

SCR Phase Control

A very simple variable resistance half-wave circuit is shown in Figure 16.16. It provides phase retard from essentially zero (SCR full "on") to 90 electrical degrees of the anode voltage wave (SCR half "on"). Diode CR1 blocks reverse gate voltage on the negative half-cycle of anode supply voltage. This protects the reverse gate junction of sensitive SCRs and keeps power dissipation low for gate resistors on the negative half cycle. The diode is rated to block at least the peak value of the AC supply voltage. The retard angle cannot be extended beyond the 90 degree point because the trigger circuit supply voltage and the trigger voltage producing the gate current to fire are in phase. At the peak of the AC supply voltage, the SCR can still be triggered with the maximum value of resistance between anode and gate. Since the SCR will trigger and latch into conduction the first time IGT is reached, its conduction cannot be delayed beyond 90 electrical degrees with this circuit.

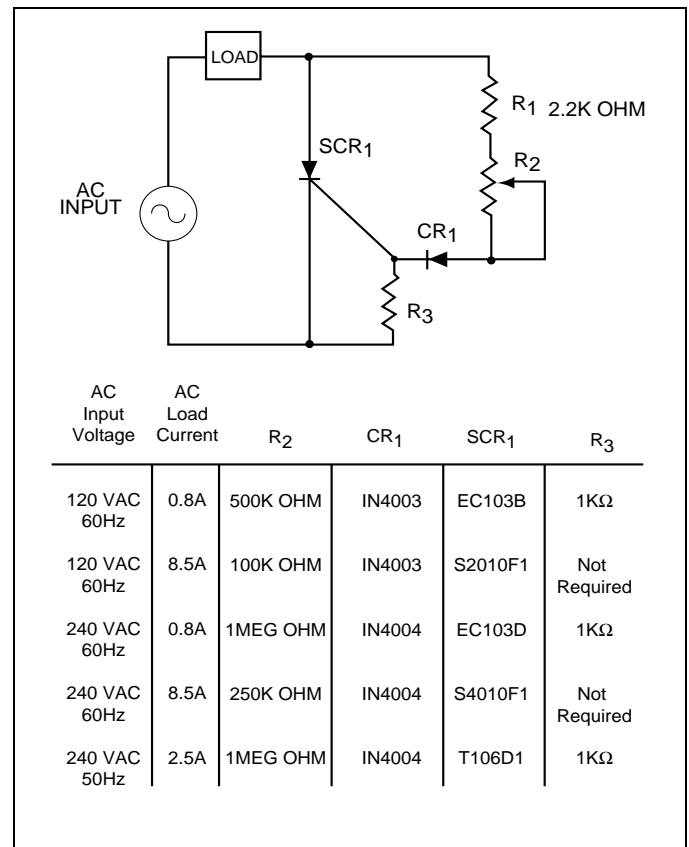

Figure 16.16 Half-Wave Control, 0-90° Conduction

Figure 16.17 is a half-wave phase control circuit using an SCR for controlling a universal motor. This circuit is better than simple resistance firing circuits because the phase-shifting characteristics of the RC network permit the firing of the SCR beyond the peak of the impressed voltage, resulting in small conduction angles and very slow speed.

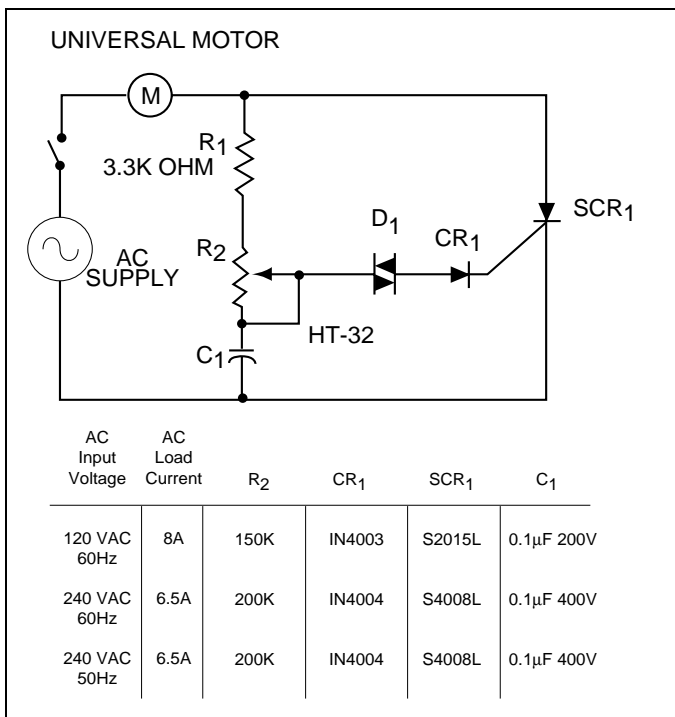

Figure 16.17 Half-Wave Motor Control

Phase Control From Logic (DC) Inputs

Triacs can also be phase controlled from pulsed DC unidirectional inputs such as produced by a digital logic control system. Therefore, a microprocessor can be interfaced to AC load by using a sensitive gate triac to control a lamp's intensity or a motor's speed.

There are two ways to interface the unidirectional logic pulse to control a triac. Figure 16.18 presents one easy way if load current is approximately 5 amps or less. The sensitive gate triac serves as a direct power switch controlled by HTL, TTL, CMOS, or integrated circuit operational amplifier. A timed pulse from the system's logic can activate the triac anywhere in the AC sine-wave producing a phase controlled load.

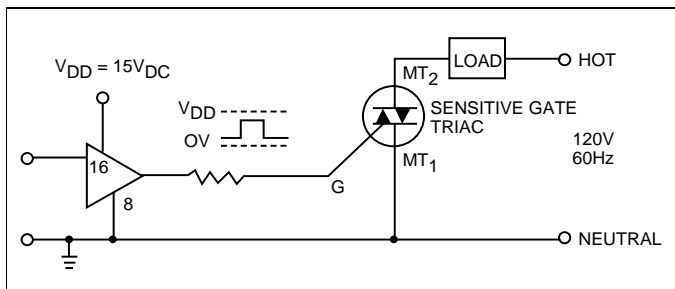

Figure 16.18 Sensitive Gate Triac Operating in Quadrants I and IV

Figure 16.19 is an example of a unidirectional (all negative) pulse furnished from a special I.C. that is available from LSI Computer Systems in Melville, New York. Even though the circuit and load is shown to control a Halogen lamp, it could be applied to a common incandescent lamp for touch controlled dimming.

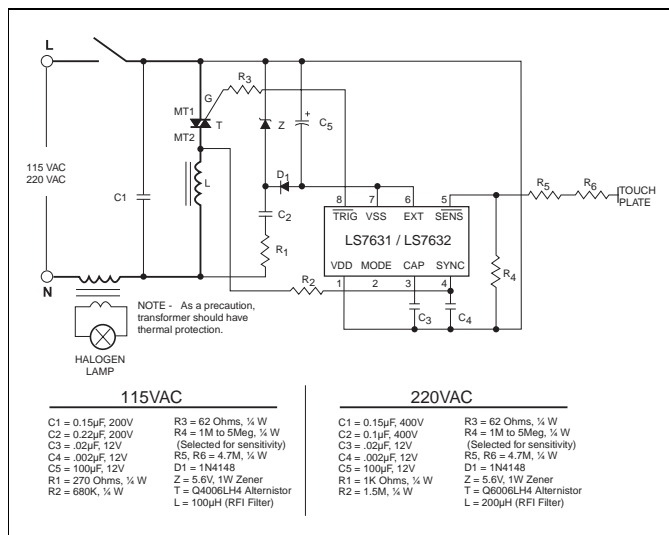

Figure 16.19 Typical Touch Plate Halogen Lamp Dimmer

For a circuit controlling heavy duty inductive loads where an Alternistor is not compatible or available. Figure 16.20 illustrates how two SCRs can be driven by an inexpensive TO-92 Triac to make a very high current Triac or Alternistor equivalent. See "Example 3: Relationship of I_{AV}, I_{RMS}, and I_{PK}" in AN1009 for design calculations.

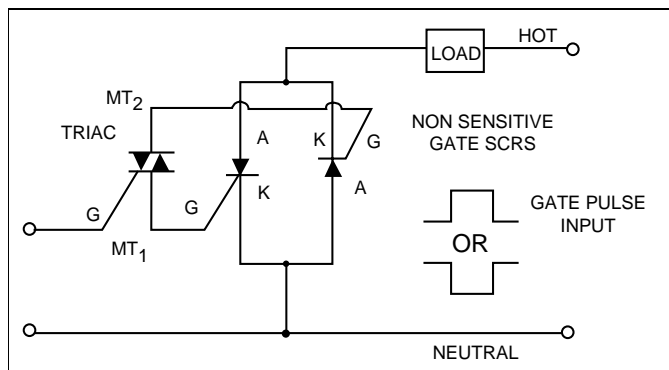

Figure 16.20 Triac Driving Two Inverse Parallel Non-Sensitive Gate SCRs

Another way to interface a unidirectional pulse signal and activate AC loads at various points in the AC sine wave is shown in Figure 16.21. This circuit has an electrically-isolated input which allows load placement, with respect to AC line, to be flexible. In other words, DC ground and AC neutral are not required to be connected.

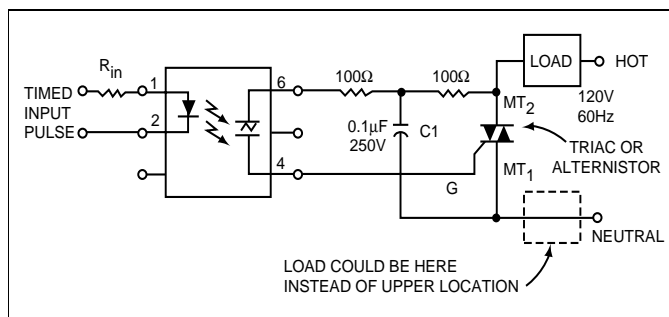

Figure 16.21 Optoisolator Driving a Triac or Alternistor

Summary

Note that the load currents that were chosen were strictly arbitrary and that the component values will be the same regardless of load current except for the power triac or SCR. The voltage rating of the power thyristor devices must be a minimum of 200V for 120V input voltage and 400V for 240V input voltage.

Also, note that the use of alternistors instead of triacs may be much more acceptable in higher current applications and may eliminate the need for any dv/dt snubber network.

For many electrical products in the consumer market, automatic control is a possibility with competitive thyristor prices and simplified circuits. These simple circuits give the designer a good feel for the nature of thyristor circuits and their design. More sophistication, such as speed and temperature feedback, can be developed as the control techniques become more familiar. A remarkable phenomenon is the degree of control obtainable with very simple circuits using thyristors. As a result, industrial and consumer products will greatly benefit both in usability and marketability.

Notes
