



Philips Semiconductors

# *PDIUSB11*

USB Device Interface





# Agenda

- **Hardware Description**
- **Command Description**
- **Command Summary**



# Hardware Descriptions

## ➤ **Block Diagrams**

**4 D11 Pin List**

**4 D11 Internal Blocks**



**Philips Semiconductors**

ASIA PRODUCT INNOVATION CENTRE

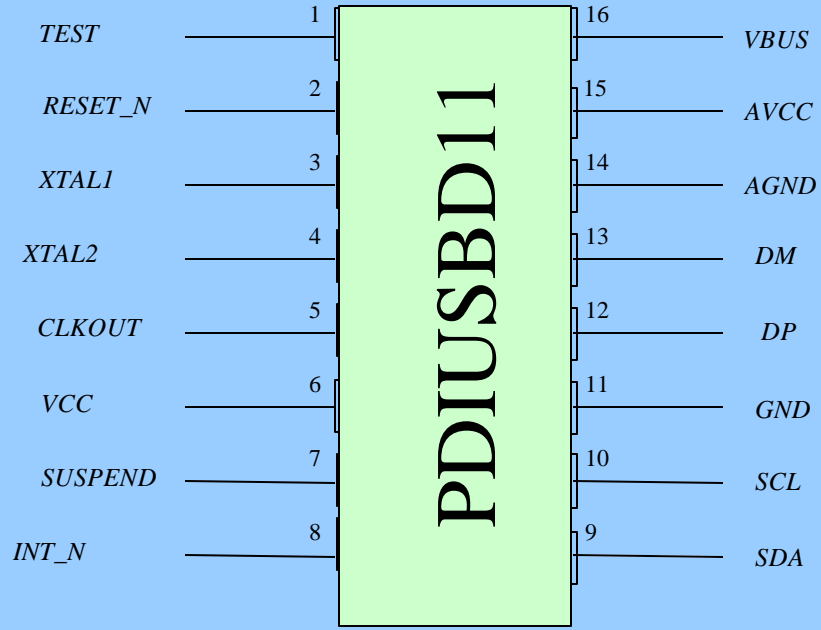

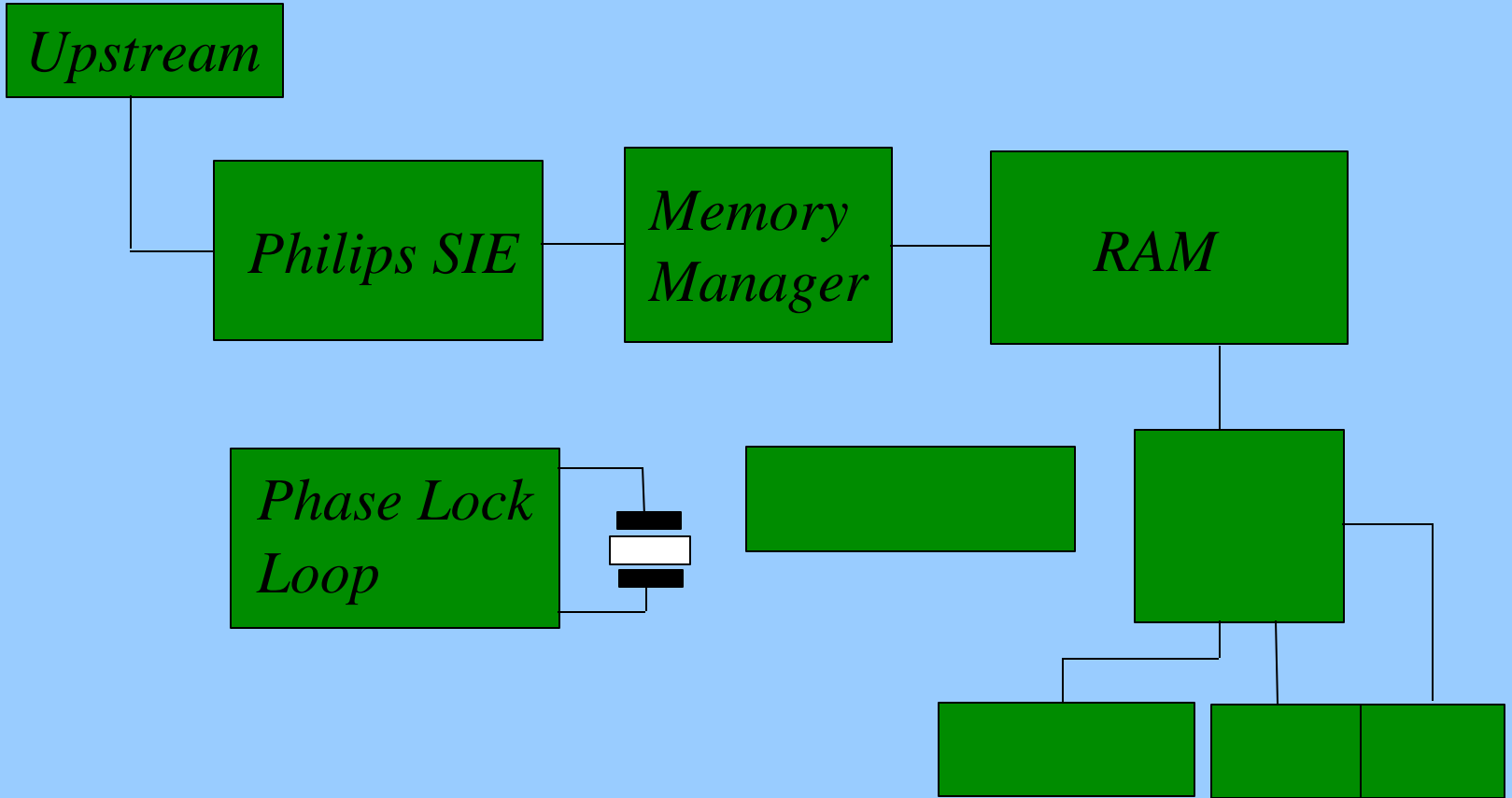



Philips Semiconductors

ASIA PRODUCT INNOVATION CENTRE

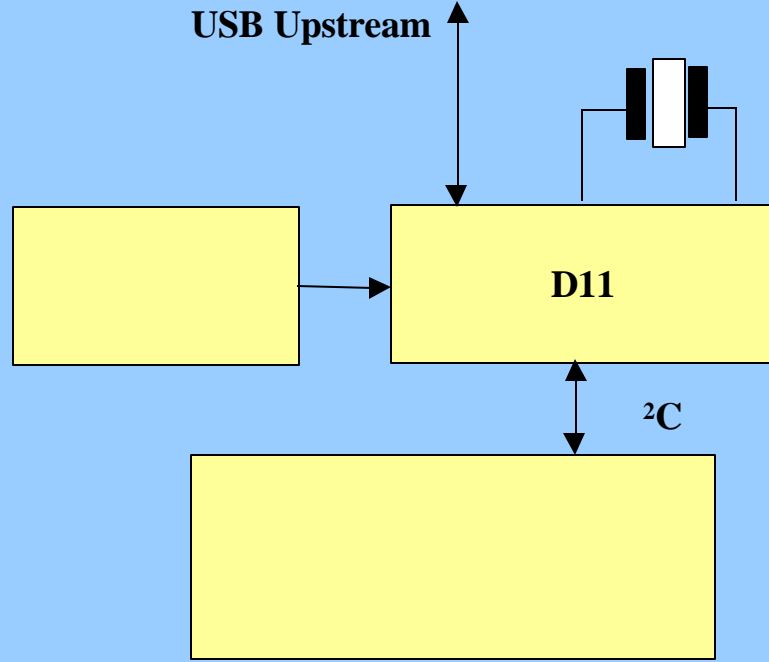



# ➤ Host Interface (I2C)

- 4 Command Transaction
- 4 Data Transaction
- 4 Read/Write
- 4 Interrupt

Command Address	0011 0110b	36h
Data Address Write	0011 0100b	34h
Data Address Read	0011 0101b	35h



# Command Description

- **Command Procedure**
- **Initialization Commands**
- **Data Flow Commands**
- **General Commands**





# ✓ Set Address/Enable

- **Command:**

- Embedded Function 1 0xD1

- **Data : Write 1 byte**

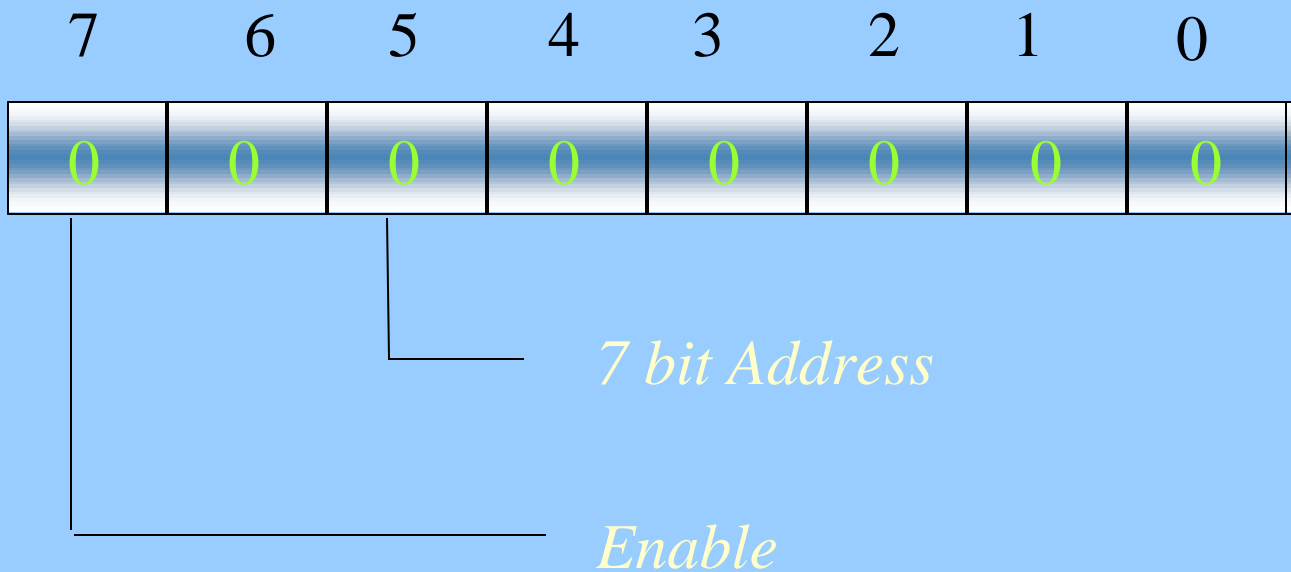



## ✓ Set Endpoint Enable

- Command : D8h
- Data: Write 1 byte

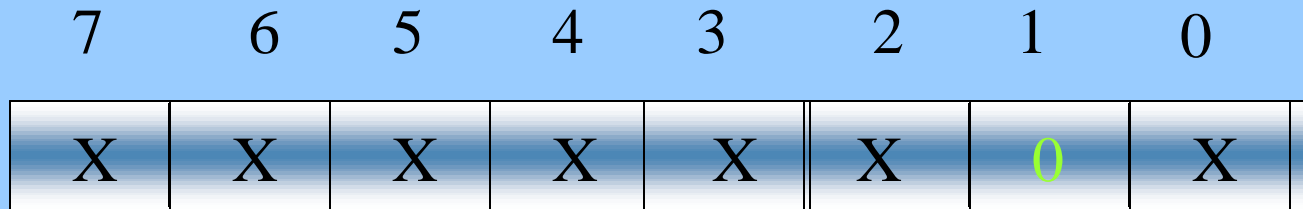

*Function Generic Endpoint*

*X - Reserved*



## ✓ Set Mode

- Command : F3h
- Data: Write 2 bytes

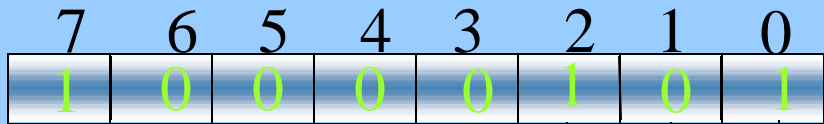

1st Byte :

**CONFIGURATION BYTE**

*Remote Wakeup*

*No Lazy Clock*

*Clock Running*

*Debug Mode*

*SoftConnect*

*Reserved (3 bits)*



## ✓ Set Mode

- Command : F3h
- Data: Write 2 bytes

7	6	5	4	3	2	1	0
X	X	X	X	1	0	1	1

2nd Byte :

CLOCK DIVISION FACTOR

*Clock Divisor N*

$$\text{CLOCK OUT} = 48 \text{ MHz} / (N + 1)$$

*X - Reserved*



# ➤ Flow Data Commands

## ✓ Read Interrupt Register

- Command: F4h
- Data: Read 2 Bytes

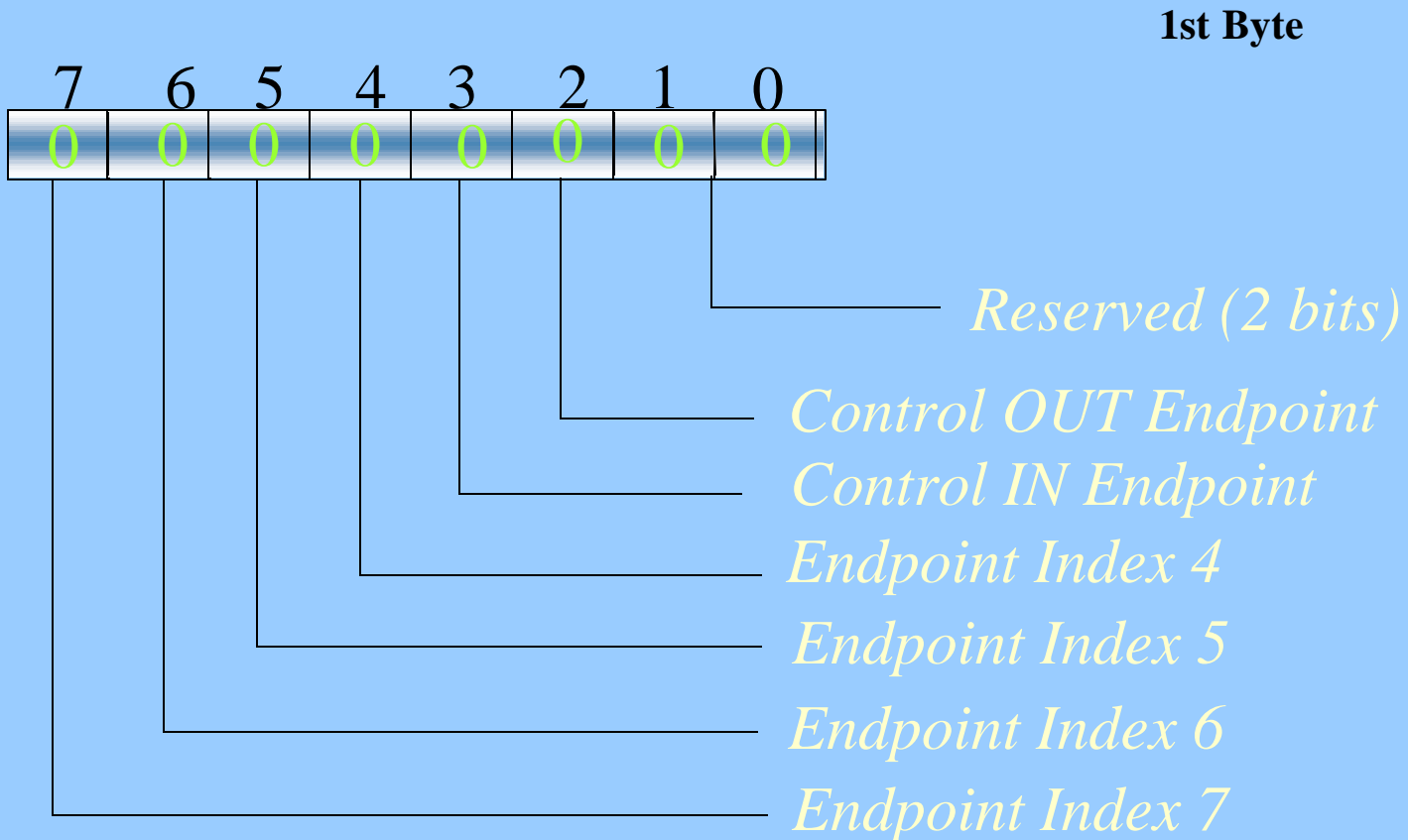



# ✓ Read Interrupt Register

- Command: F4h
- Data: Read 2 Bytes

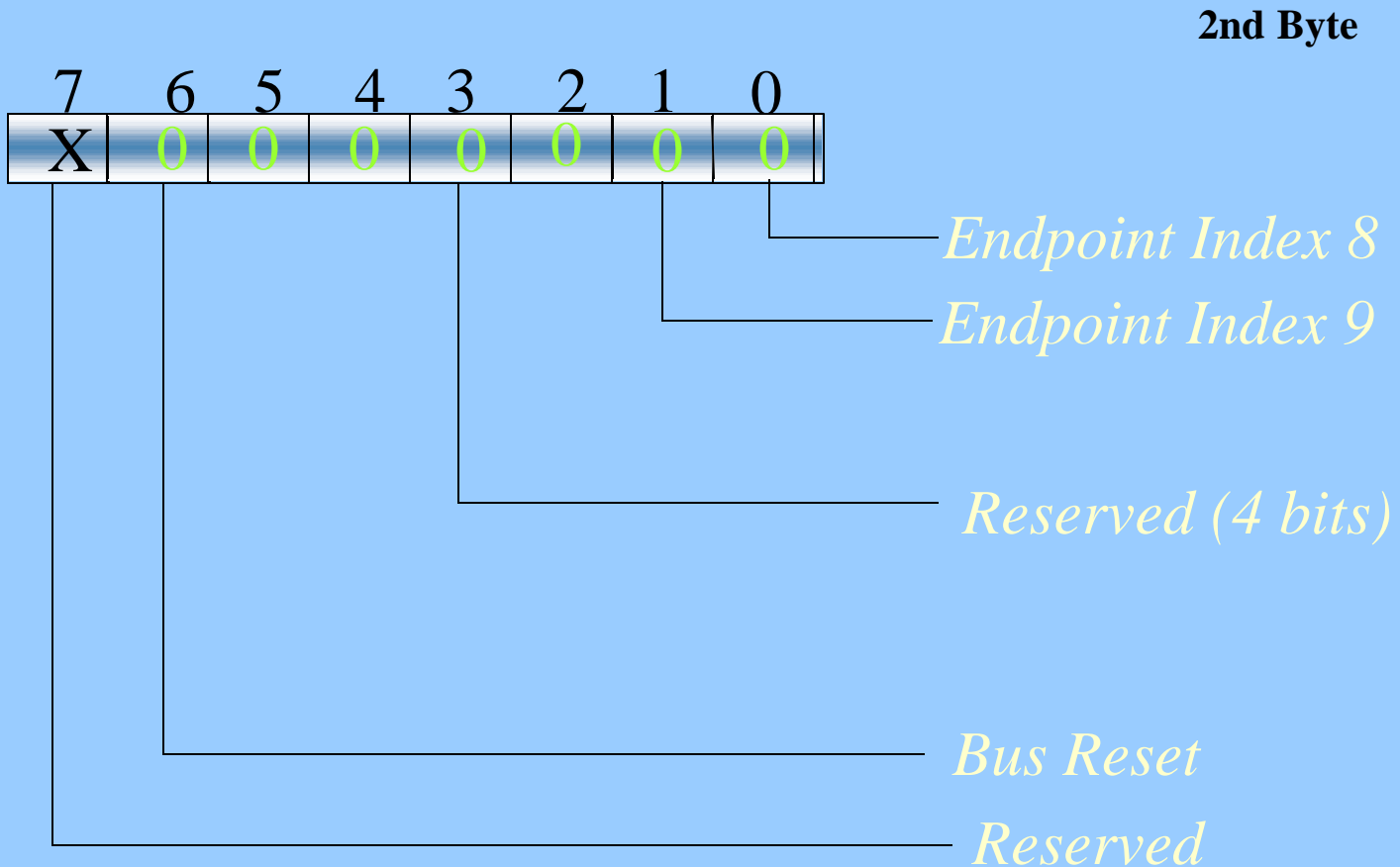



# ✓ Read Last Transaction Status

- Command: 40-4Dh
- Data: Read 1 byte (Clears the interrupt source)

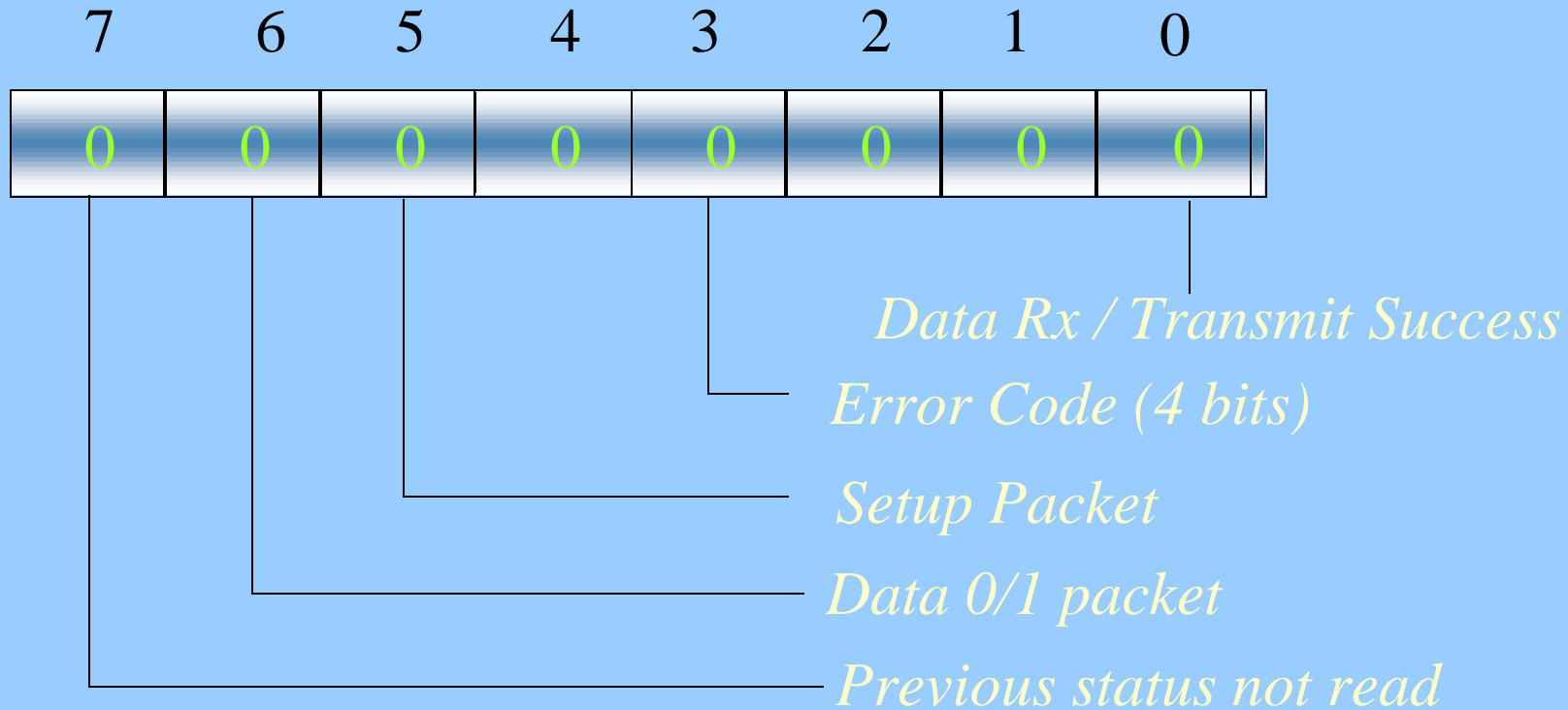



# ✓ Read Endpoint Status

- Command: 80-8Dh
- Data: Read 1 byte

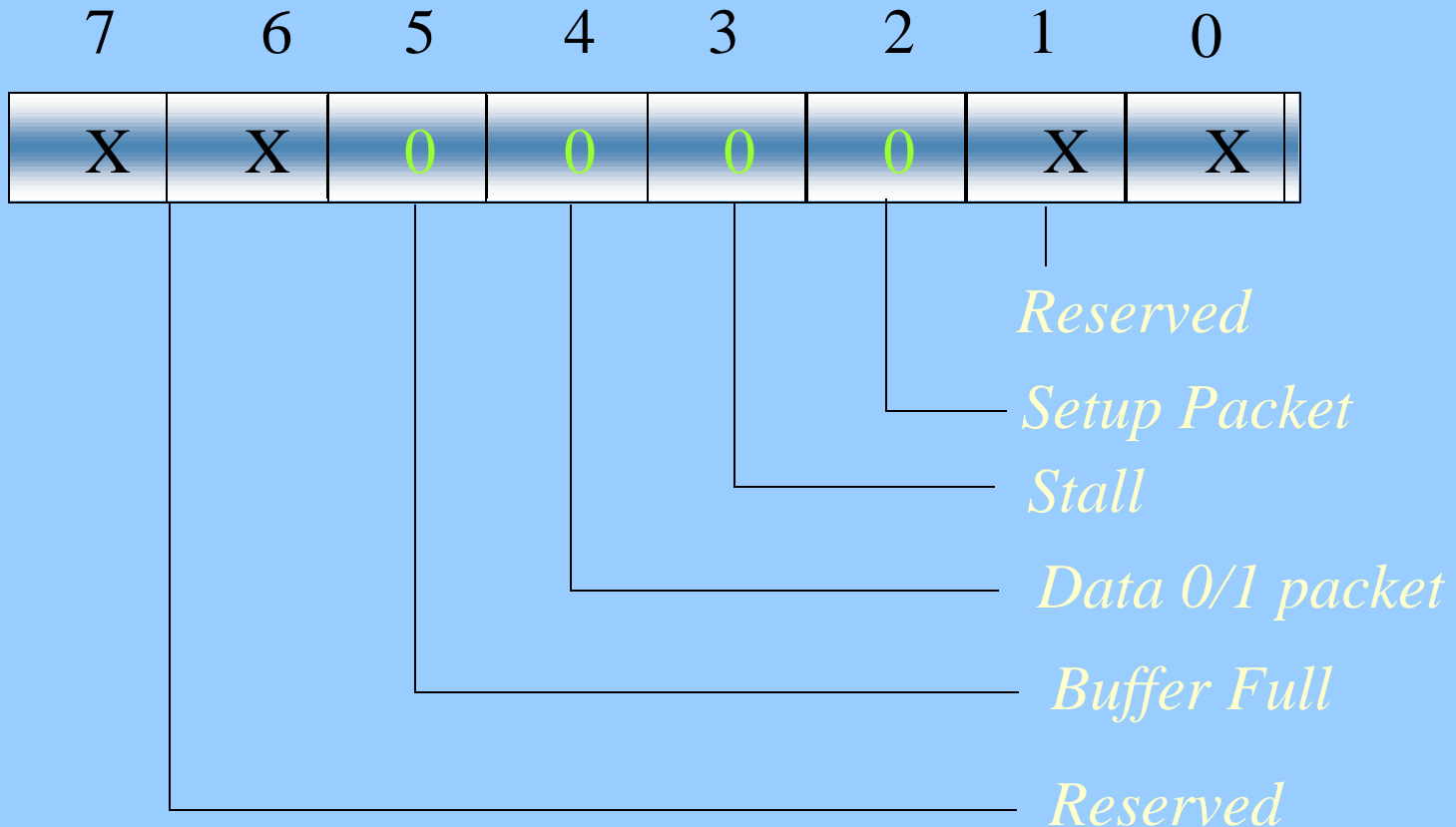





# ✓ Select Endpoint

- **Command**

- Emb Fn Endpoint Index       $0x00 + \text{Index}$

- **Data: Optional Read**

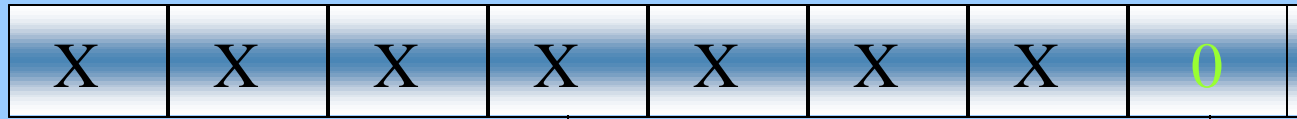

*Reserved*

*Full/Empty*



## ✓ Read Buffer

- Command: F0h
- Data: Read (Multiples Bytes)

The Data in the buffer is organized as follows:

byte 1: Number of byte in the buffer

byte 2: Data byte 1

byte 3: Data byte 2



## ✓ Write Buffer

- Command F0h
- Data: Write (One or more Bytes)

Data must be organized in the same way as described in

## ➤ Data Flow Commands

### ✓ Clear Buffer

- Command: F2h
- Data: No Data



## ✓ Validate Buffer

- Command: FAh
- Data: No Data



## ➤ Data Flow Commands

### ✓ Set Endpoint Status

- Command: 0x40 - 0x4D
  - Function Endpoint 0x40+Index
- Data: Write

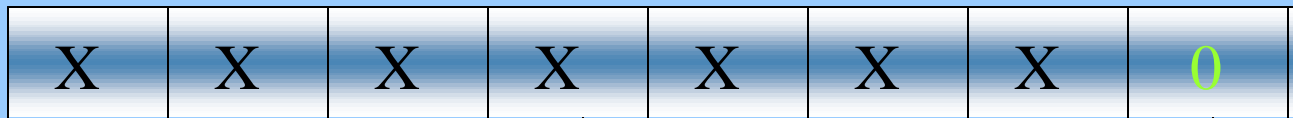



## ➤ Data Flow Commands

### ✓ Acknowledge Setup

- Command                      F1h
- Data: No Data



## ➤ **General Commands**

### ✓ **Send Resume**

- **Command: F6h**
- **Data: None**



# ➤ General Commands

## ✓ Read Current Frame Number

- Command: F5h
- Data: Read one or two bytes

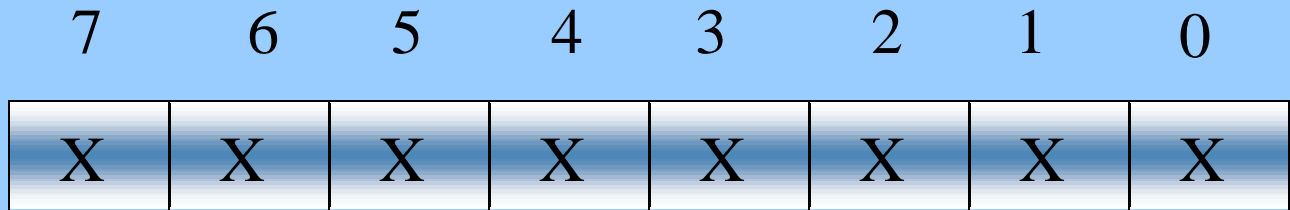

*LSByte*

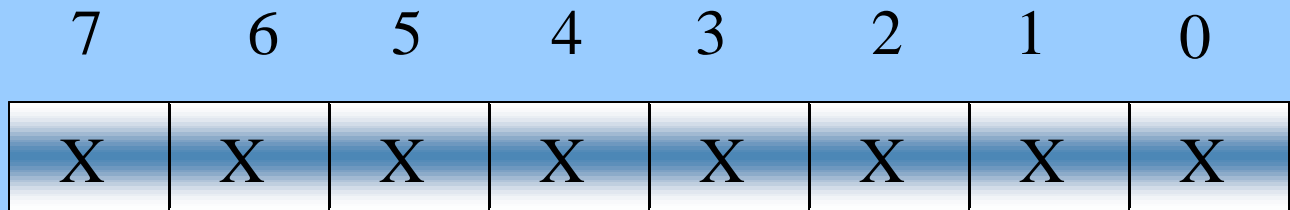

*MSByte*





# ➤ Command Summary

Command Name	Recipient	R/W	Data	Coding
<b>Initialization Commands</b>				
Set Address/Enable	Emb Fn	W	1	D1h
Set Endpoint Enable	Emb Fn	W	1	D8h
Set Mode		W	2	F3h
<b>Data Flow Commands</b>				
Read Interrupt Register		R	1	F4h
Read Endpoint Status	Emb Fn	R	1	80h+index



Command Name	Recipient	R/W	Data	Coding
Select Endpoint				
	Emb Fn	R*	1	00h+index
Read Buffer	Selected Endpoint	R	X	F0h
Write Buffer	Selected Endpoint	W	X	F0h
Set Endpoint Status				
	Emb Fn	W	1	40h+index
Acknowledge Setup	Selected Ep	X	none	F1h
Clear Buffer	Selected Ep	X	none	F2h
Validate Buffer	Selected Ep	X	none	FAh



Command Name	Recipient	R/W	Data	Coding
<b>General Commands</b>				
Send Resume			none	F6h
Read Current Frame Number		R	1 or 2	F5h